

HIAB X-CL 19



HIAB X-CL 19 BASIC DATA

BASIC DATA	X-CL 19 B-2	X-CL 19 B-3
Mdyn	215 kNm	217 kNm
Lifting capacity (kNm)	169.4	164.8
Lifting capacity (tm)	17.3	16.8
Outreach - lifting capacity, standard (m-kg)	3.2 - 5 400 4.6 - 3 750 6.4 - 2 650 8.4 - 2 020	3.4 - 4 950 4.6 - 3 600 6.4 - 2 500 8.4 - 1 860 10.4 - 1 500
Outreach - lifting capacity, manual extensions (m-kg)	10.4 - 1 540	-
Hydraulic outreach, standard (m)	8.6	10.8
Hydraulic boom extension (m)	3.9	6.0
Outreach, manual extensions (m)	10.8	-
Lifting height above installation level, hydr/man (m)	11.1/13.2	13.1/-
Rec. oil flow (l/min)	20 - 30	20 - 30
Working pressure (Mpa)	33.0	33.0
Oil in tank (l)	70 - 200	70 - 200
Tank capacity (l)	0 - 235	0 - 235
Slewing angle (°)	415	415
Max slope viable at full capacity (°)	6.4	6.4
Slewing torque, gross (kNm)	28.3	28.3
Lifting speed at standard hydraulic outreach (m/s)	0.7	0.9
Height in folded position (mm)	2265	2265
Width in folded position (mm)	2485	2485
Install space required (mm)	865	950
Crane in standard version without stabiliser system (kg)	1 760	1 920
Frame attachments (kg)	65	65
Stabiliser system equipment (kg)	271 - 319	271 - 319

This table show one example of a model, and represents some of all options available. With the opportunity to configure your crane, we can provide you with a crane perfectly tailored to your needs. Please contact your local dealer for more information and the exact data on the variety of options we can offer.

Hiab X-CL 19 B-2

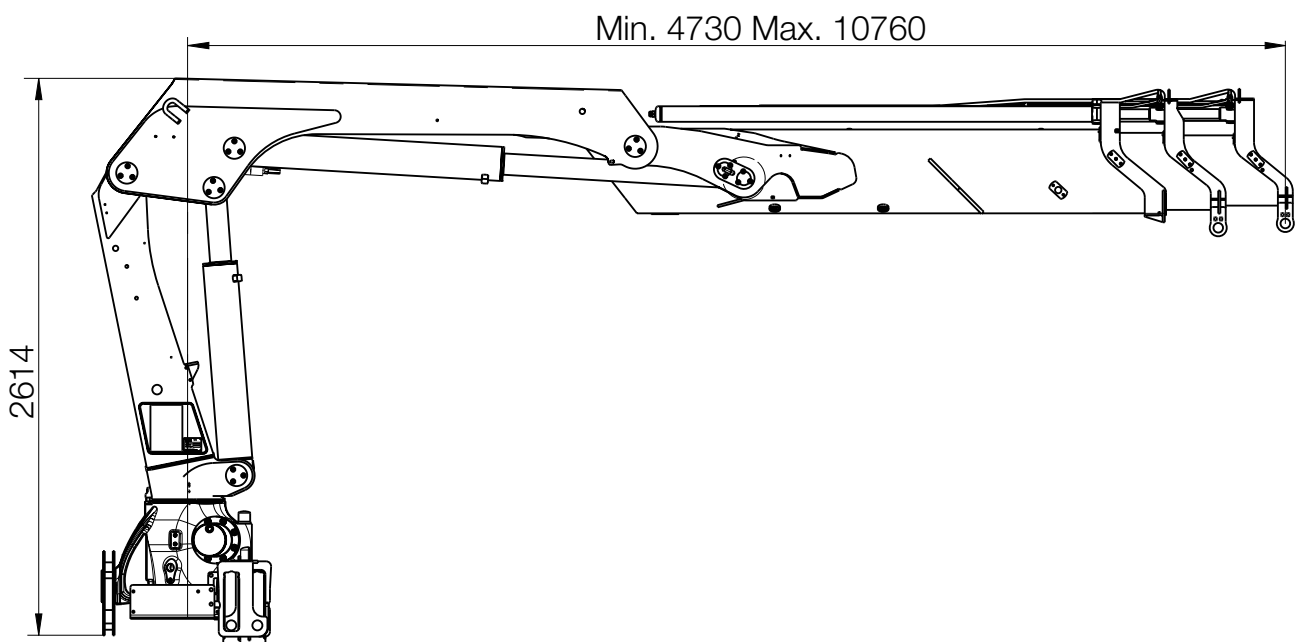
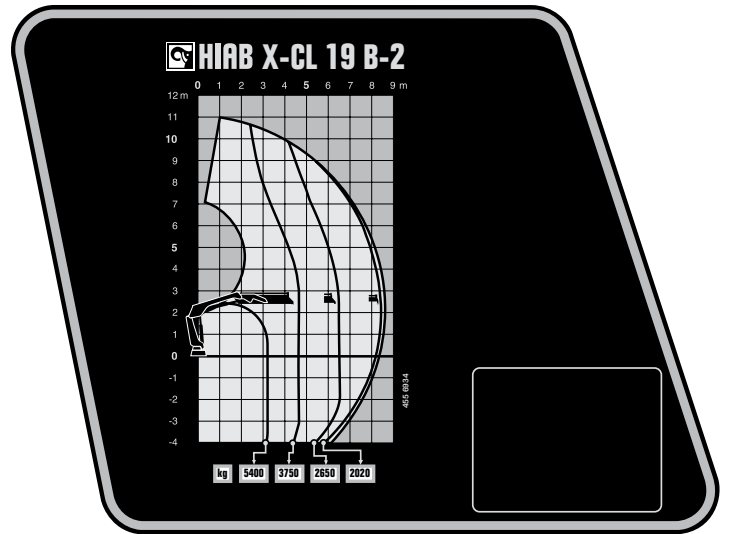
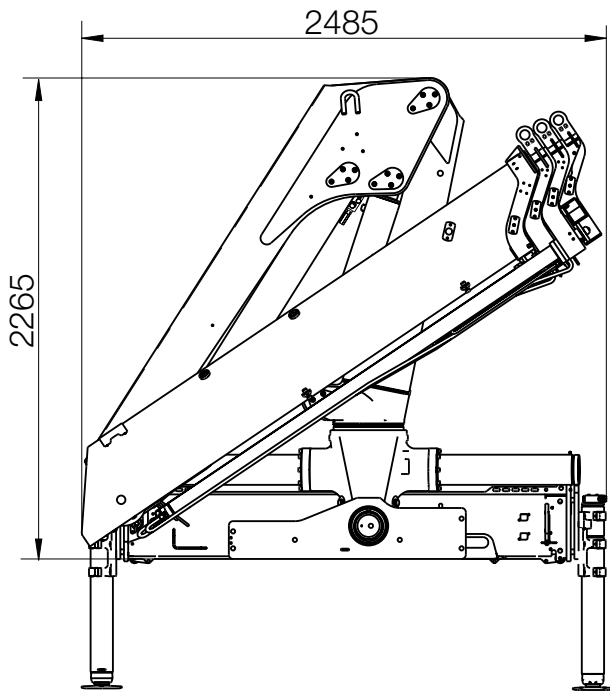

BUILT TO PERFORM

Hiab is the world's leading provider of on-road load handling equipment. Customer satisfaction is the first priority for us. Hiab's product range includes HIAB loader cranes, JONSERED recycling and forestry cranes, LOGLIFT forestry cranes, MOFFETT truck mounted forklifts and MULTILIFT demountables, as well as DEL, WALTCO and ZEPRO tail lifts.

hiab.com

Hiab is part of Cargotec.

cargotec.com



© BD-XCL19-EN-WW-170915



hiab.com