

HIAB X-CLX 328 EP



HIAB X-CLX 328 EP BASIC DATA

TECHNICAL DATA	X-CLX 328 EP-2	X-CLX 328 EP-3	X-CLX 328 EP-4	X-CLX 328EP-5
Mdyn	381 kNm	390 kNm	396 kNm	401 kNm
Lifting capacity (kNm)	297	291	284	279
Lifting capacity (tm)	30.3	29.7	29.0	28.5
Outreach - lifting capacity, standard (m-kg)	2.9 - 10 000 4.2 - 7 300 6.0 - 5 100 8.0 - 3 800	2.8 - 10 000 4.3 - 7 000 6.0 - 4 950 8.0 - 3 650 10.2 - 2 850	2.8 - 10 000 4.4 - 6 700 6.1 - 4 700 8.1 - 3 400 10.3 - 2 600 12.6 - 2 120	2.7 - 10 000 4.5 - 6 400 6.2 - 4 500 8.2 - 3 250 10.4 - 2 440 12.7 - 1 960 15.0 - 1 640
Outreach - lifting capacity, manual extensions (m-kg)	-	-	-	17.4 - 1 340
Hydraulic outreach, standard (m)	8.0	10.3	12.7	15.1
Hydraulic boom extension (m)	3.8	6.0	8.3	10.6
Outreach, manual extensions (m)	-	-	-	17.6
Lifting height above installation level, hydr/man (m)	10.6 / -	12.9 / -	15.2 / -	17.6- 20
Rec. oil flow (l/min)	60 - 90	60 - 90	60 - 90	60 - 90
Working pressure (Mpa)	32.0	32.0	32.0	32.0
Slewing angle (°)	420	420	420	420
Max slope viable at full capacity (°)	3	3	3	3
Height in folded position (mm)	2 380	2 380	2 380	2 380
Width in folded position (mm)	2 495	2 495	2 497	2 497
Install space required (mm)	1120	1 198	1 239	1 239
Crane weight in standard version without stabiliser system (kg)	2 991	3 201	3 405	3 563
Frame attachments (kg)	69 - 89	69 - 89	69 - 89	69 - 89
Stabiliser system (kg)	454 - 556	454 - 556	454 - 556	454 - 556

This table shows one example of a model, and represents some of all options available. With the opportunity to configure your crane, we can provide you with a crane perfectly tailored to your needs.

Please contact your local dealer for more information and the exact data on the variety of options we can offer.

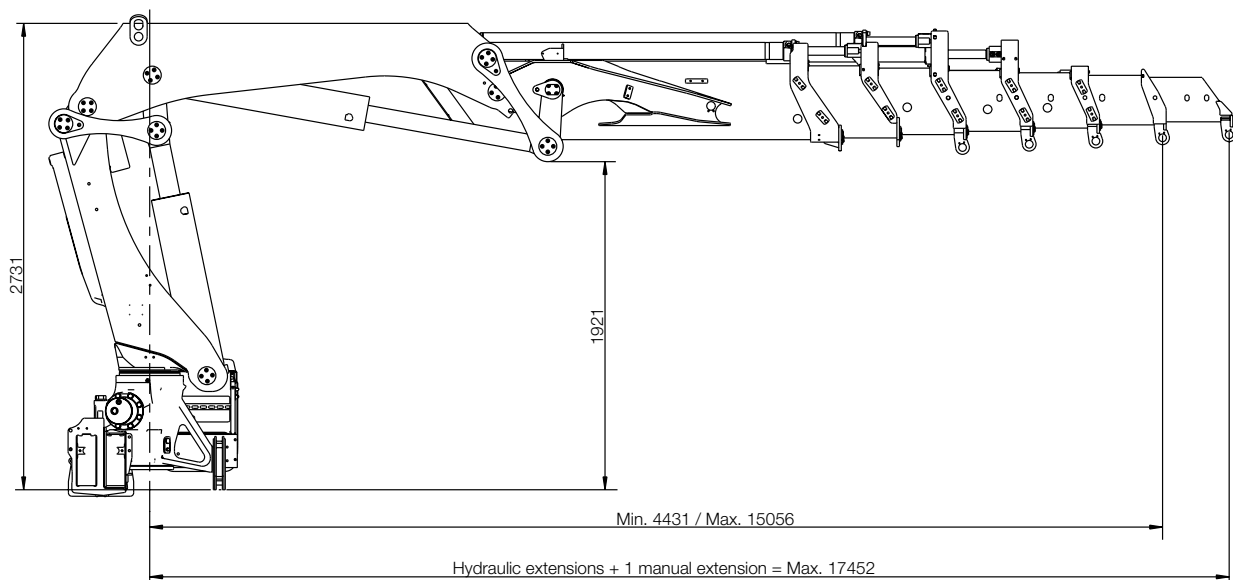

HIAB X-CLX 328 EP-5

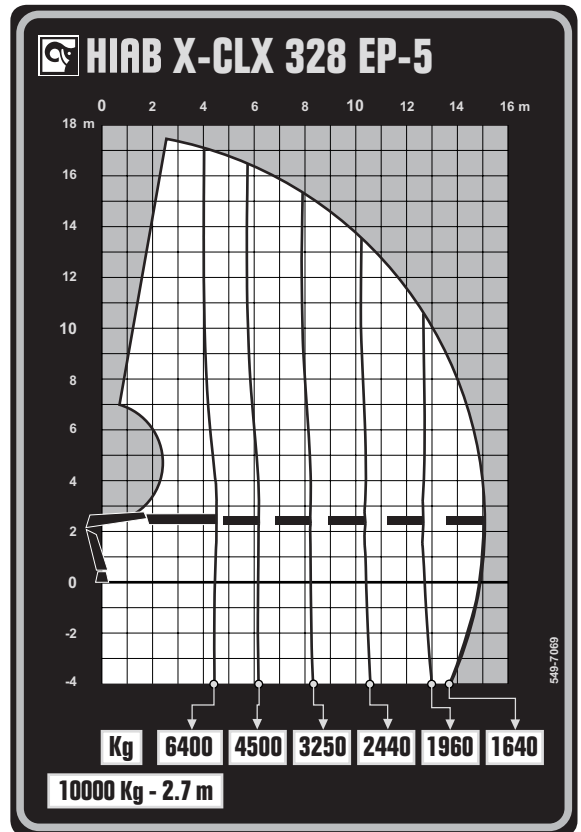
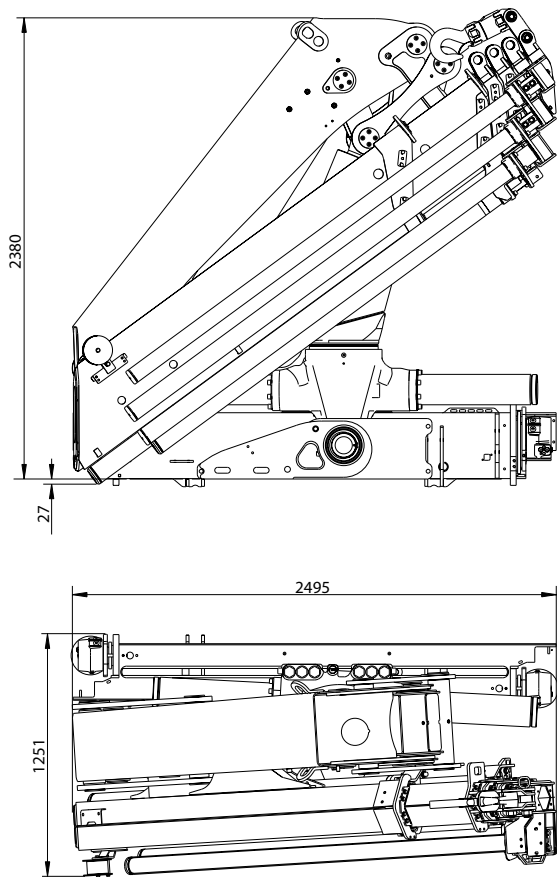

X	Y
700	2 338
1 000	2 462

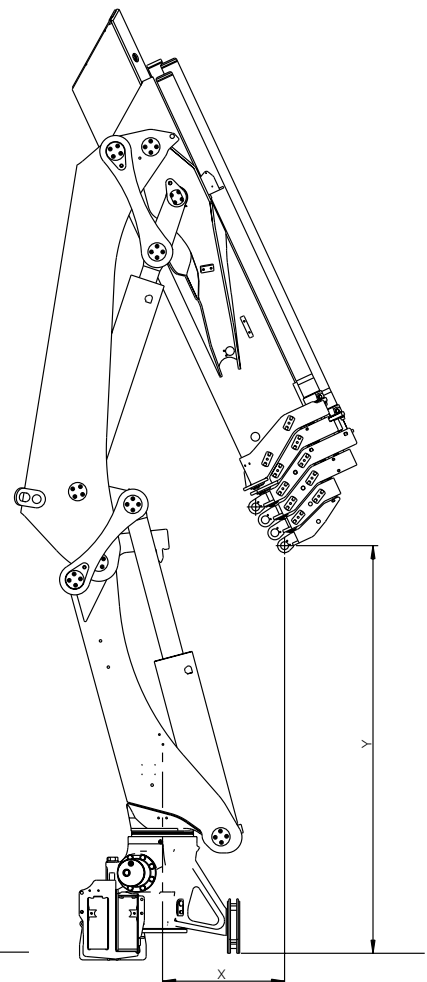
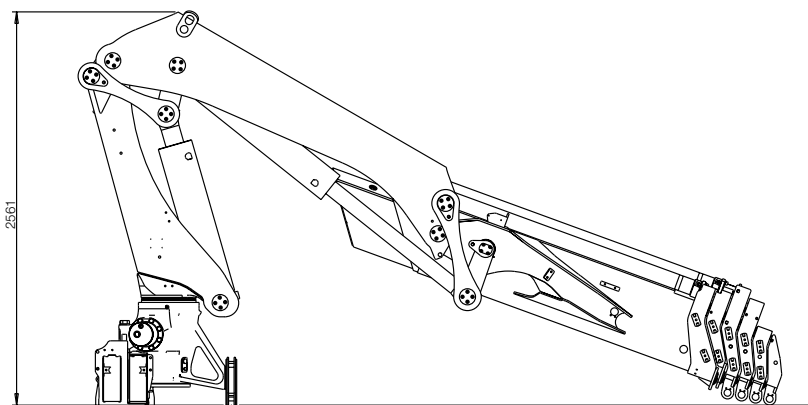

BUILT TO PERFORM

Hiab is the world's leading provider of on-road load handling equipment. Customer satisfaction is the first priority for us. Hiab's product range includes HIAB loader cranes, JONSERED recycling and forestry cranes, LOGLIFT forestry cranes, MOFFETT truck mounted forklifts and MULTILIFT demountables, as well as DEL, WALTCO and ZEPRO tail lifts.

hiab.com

Hiab is part of Cargotec.

cargotec.com



© BD-XCLX328EP-EN-WW_171121



hiab.com

